



SPECIFICATION

Application Medium	Portable Water and Sewage
Valve Size	DN50 to DN600
Design and manufacture	BS EN 1074-2, BS 5163 Pt. 1&2,
Face to Face Dimension	BS EN 558-1 Series 3
End Connection	Flanged End BS EN 1092-2 PN16
Working Pressure	Maximum 16 Bar
Working Temperature	Up to 80°C
Actuation	Stem Cap, Handwheel Operated
Test Pressure (Hydrostatic)	Shell Test 24 Bar, Seat Test 17.6 Bar
Optional	By-Pass Valve, Position Indicator

GATE VALVE RESILIENT SEATED DUCTILE IRON

MATERIALS

PARTS	MATERIALS	BS DESIGNATION / GRADE
1. Body	Ductile Iron (FBE coated)	BS EN 1563 Grade 500/7
2. Wedge	Ductile Iron Vulcanized EPDM	BS EN 1563 Grade 500/7 + EN 681
3. Stem Nut	Gunmetal	BS 1400 LG2
4. Stem	Stainless Steel	BS 970 Part 1 431S29
5. Bonnet Gasket	EPDM	BS EN 681-1
6. Bonnet	Ductile Iron (FBE coated)	BS EN 1563 Grade 500/7
7. Sleeve O-ring Seal (lower)	EPDM	BS EN 681-1
8. Sealing Sleeve	Gunmetal	BS 1400 LG2
9. Sleeve O-ring Seal (upper)	EPDM	BS EN 681-1
10. Stem O-Ring Seals	EPDM	BS EN 681-1
11. Gland	Ductile Iron (FBE coated)	BS EN 1563 Grade 500/7
12. Dust Guard	EPDM	BS EN 681-1
13. Gland Bolts	Stainless Steel	BS 970 Part 1 431S29
14. Bonnet Fastener	Stainless Steel	BS 970 Part 1 431S29
15. Thrust Collar	Gunmetal	BS 1400 LG2

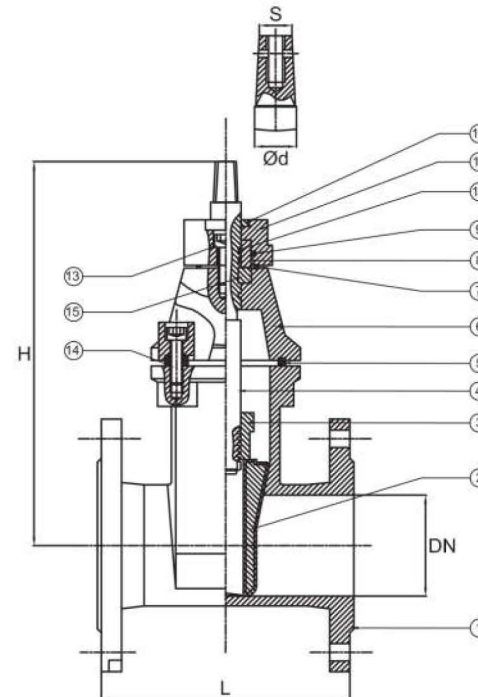

FIG 6N3B

DIMENSIONS (mm)

Size	inch	2	2½	3	4	5	6	8	10	12	14	16	18	20	24
	mm	50	65	80	100	125	150	200	250	300	350	400	450	500	600
L		178	190	203	229	254	267	292	330	356	381	406	432	457	508
H		218	235	255	300	350	392	485	585	655	760	832	860	995	1160
Ød		20	20	24	24	26	26	28	30	32	34	38	40	40	42
Weight (Kg)		10	13	17	22	28	38	58	88	125	200	280	350	400	580

*The specifications are subject to change without further notice