



APPLICATION

Suitable for water, oil, gasses and non-abrasive media
(Refer to corrosion resistance table for valve materials selection).

SPECIFICATION

End Connection Screwed End BSPT
Nominal Pressure 16 Bar
Working Temperature Up to 120°C
Test Pressure Conform to ISO 5208

MATERIALS

PARTS	FIG. 18S1
1. Body	Brass
2. Float	Heat Resistance Resin
3. O-ring	EPDM
4. Seat	Brass
5. Cover	Brass
6. Plug	Brass B16 (CuZn39Pb3)

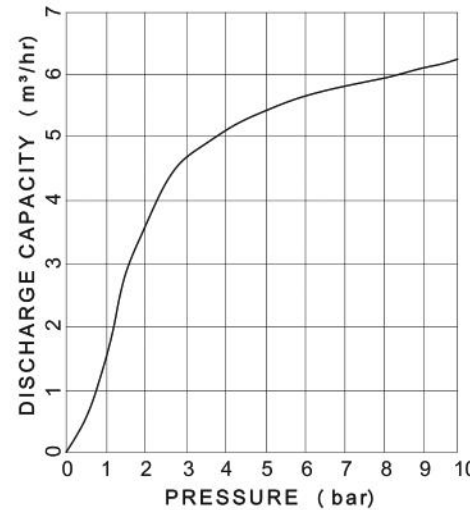
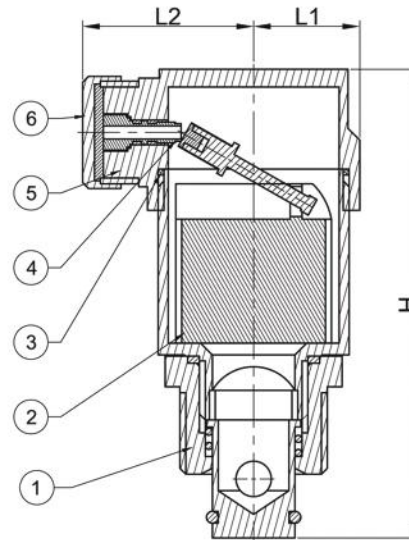

AUTOMATIC AIR VENT

BRASS



DIMENSIONS (mm)

Size	Inlet Size	L1	L2	H
15A	1/2" BSPT	19	30	75
20A	3/4" BSPT	19	30	75
25A	1" BSPT	19	30	75

FIG 18S

*The specifications are subject to change without further notice